

titan

INSTRUCTION MANUAL

PROCESS atrato™



Ultrasonic Flowmeter Range

PROCESS
atrato ™

CONTENTS**Page No**

1	General	4
2	Order Codes	4
3	Installation	5 & 6
4	Specifications	7 & 8

1 General

The Process Atrato represents a new generation of through bore time of flight ultrasonic flowmeters that uses breakthrough technology to offer a wide ranging yet accurate meter. It is ideal for many process control, instrumentation and laboratory applications. The user must make sure that the flowmeter selected is suitable for the application and that the chemical compatibility, temperature and pressure requirements are within the Process Atrato's operating range. Please check the model number before proceeding.

2 Order Codes

First 3 digits Standard Flow range

71P = 2 - 500 mL/min

72P = 0.01 - 1.5 L/min

74P = 0.03 - 5 L/min

76P = 0.1 - 15 L/min

Fourth digit seal material

V = Viton®

N = Nitrile

E = EPDM

S = Silicon

K = Kalrez®

Fifth digit process fittings

Q = 1/4"

Sixth digit Thread type

B = BSP

N = NPT

Seventh digit Tube assembly materials

0 = PEEK/316 St St

S = Special

For example

76P - VQB - 0

This is a 15 L/Min flowmeter with Viton seals, quarter inch BSP fittings and a 316 stainless steel body with stainless steel and PEEK flow tube.

3 Installation

- The flowmeter includes a 180° loop of pipe which has the potential of trapping vapour at low fluid velocities which will seriously modulate the ultrasonic signals. Position the meter either in a horizontal pipe or in a vertical pipe with the flow in an upward direction. Take care to observe the 'Flow Direction' arrow on the flowmeter body.
- In a horizontal pipe ensure that the pipe connections are towards the top edge of the meter so that the majority of the body and hence the flow loop is below the line of the pipe. If vertical is not possible an angle of more than 30 degrees from the horizontal would be acceptable. (See diagram on page 6).
- Due to the internal flow path straight upstream and downstream pipes are not necessary.
- It is however good practice to install the device well away from valves, regulators, bends and other components that could cause excessive turbulence or gas break-out on the fluid entering or leaving the meter. Do not position the meter in close proximity to strong electromagnetic field or disturbances such as inverters, motors and solenoids.
- If necessary use spacer blocks and mounting clips to raise the pipe work away from surfaces.
- It is good practice to use upstream and downstream isolating full bore ball valves and a bypass to facilitate easy meter installation or removal.
- The Process Atrato must be installed in a positive pressure system. Ensure that there is sufficient back pressure on the flowmeter to keep any gas in solution. We recommend at least 500mbar plus two times the fluid vapour pressure at all flow rates. Lower pressures may result in signal loss at higher flows.

Two multi-coloured LEDs display system information.

The upper LED displays signal condition using the colour to show the signal strength:-

Good signal	=	Green
Poor signal	=	Orange
Bad or no signal	=	Red (possible causes: air in line or fluid, attenuating or otherwise incompatible fluid)

The lower LED displays information regarding the power supply and pulse output:-

Incorrect voltage	=	Red
Voltage within range	=	Green

3 Installation

If flow is present the LED will flash to show a pulse output. The rate of the flashing is related to the flow rate.

Note. If the meter is subjected to heavy pulsations in the flow, for example from a diaphragm pump, it is recommended that a pressure regulator and a pulsation damper are installed up stream of the flowmeter. The Process Atrato's internal cycle time is not adjustable and should this measurement period coincide with, or be close to, the pulsations in the flow errors in the flow calculations will occur.

Gases seriously modulate the ultrasound and should be avoided. Always install the meter in a way that any trapped vapour can escape the flow measurement section. i.e. in a horizontal line with the electrical connection at the bottom or in a vertical line with the flow upwards.

The meters are normally calibrated on water with a velocity of sound of approximately 1488m/s. The meters velocity of sound operating window is nominally 1488m/s \pm 30%. Should your process parameters exceed this please contact your local sales office as special calibration may be required.

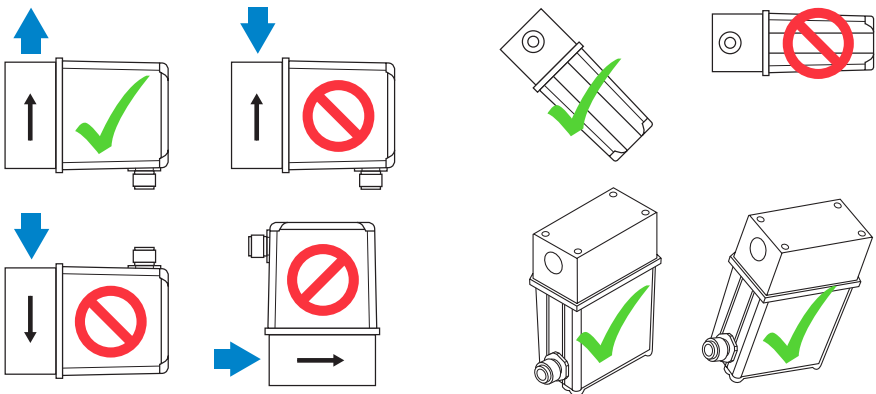

Observe direction of flow arrow on steel body

Plastic cap should always be positioned lower than flow tube and steel body

4 Specifications

Flow range	71P = 2 to 500 ml/min — 100000 pulses per litre 72P = 0.01 to 1.5 l/min — 20000 pulses per litre 74P = 0.03 to 5 l/min — 10000 pulses per litre 76P = 0.1 to 15 l/min — 2000 pulses per litre
Linearity	±1.0% of reading from 2 to 100% of range ±2.0% of reading from minimum flow to 2% of range
Repeatability	±0.1% of reading plus 0.005% of full scale
Housing	IP65
Temperature range	-20 to 65°C non-condensing
Power	+8 to 24V dc 100mA typical (+5 to 24V dc with regulated dc power supply)
Process connections	1/4" BSP/NPT
Outputs	NPN pulse. Max 20mA max PNP pulse. Max 20mA max
Weight	350g

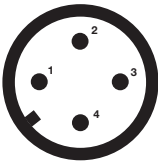

Output Pinout

- Pin 1.** +8 to 24V dc
- Pin 2.** PNP transistor output
- Pin 3.** 0 Volts
- Pin 4.** NPN transistor output

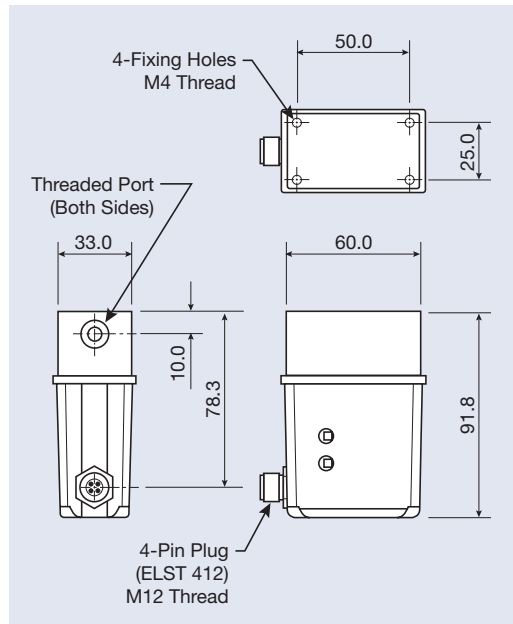

4 Specifications

Process Atrato

- Linearity - Green line $\pm 1.0\%$ of reading from 2 to 100% of range
- Black line $\pm 2.0\%$ of reading minimum flow to 2% of range
- Repeatability - Red line $\pm 0.1\%$ of reading plus 0.005% of full scale

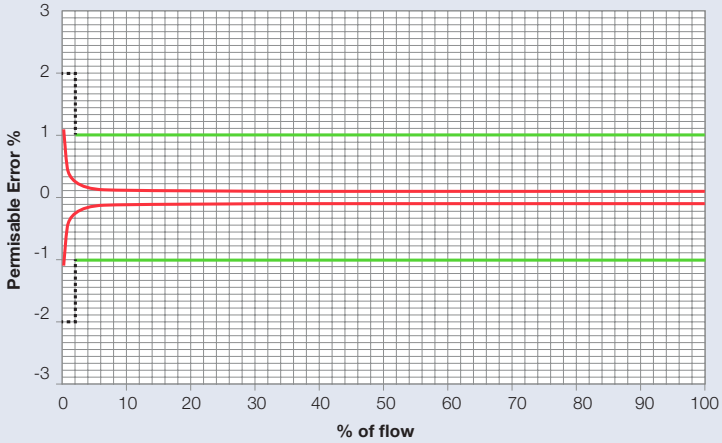

Pressure drop versus flow for Process Atrato

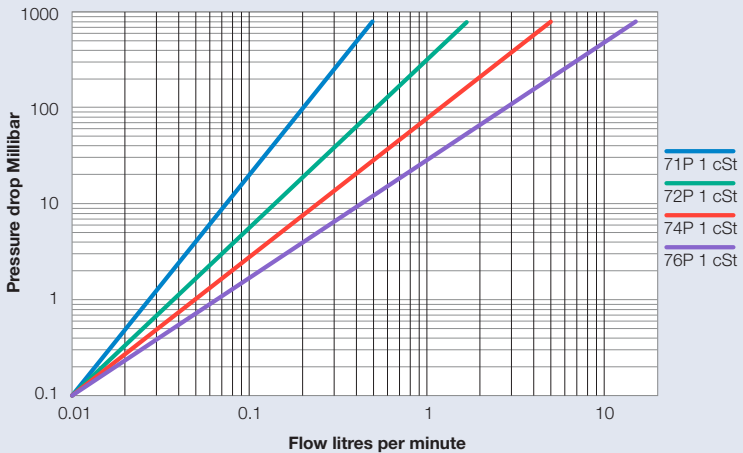

Distributed by:-

titán

TITAN ENTERPRISES LTD.

Coldharbour Business Park, Sherborne, Dorset DT9 4JW

Phone: +44 (0)1935 812790

Email: sales@atratoflowmeters.com

www.atratoflowmeters.com